

5000 & 5500 Alarm Exit Hardware

8000 & 8500 Alarm Exit Hardware

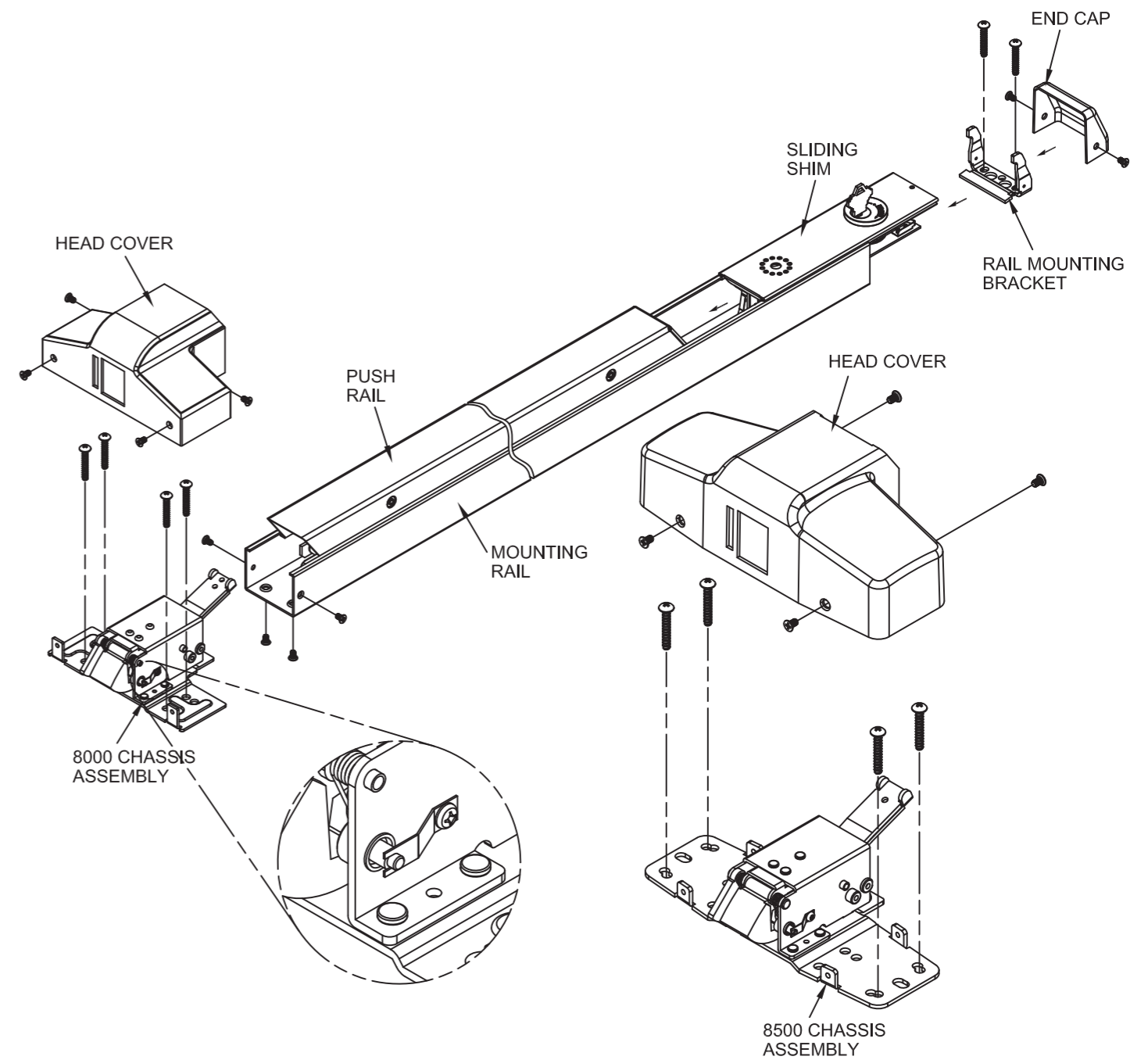
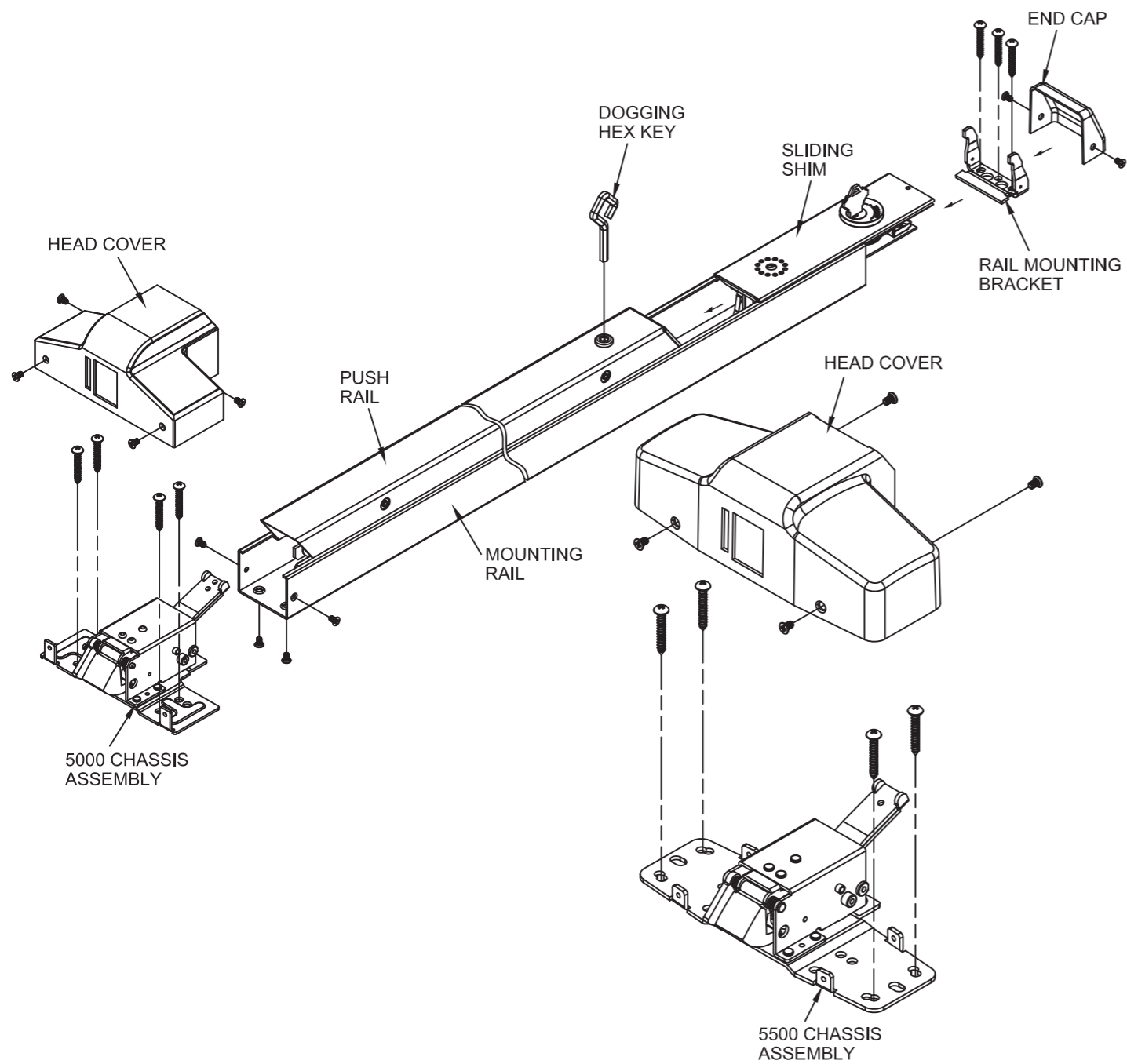
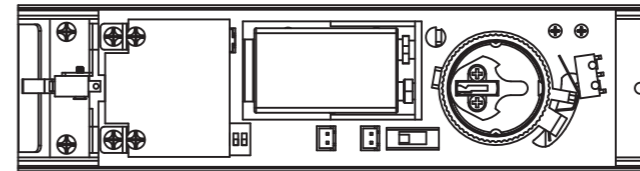
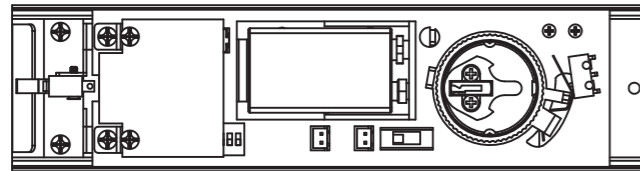

Rim Type Exit Devices

- 1.5000 / 5500 - 36 Alarm rim type 36" door (panic grade).
- 2.5000 / 5500 - 48 Alarm rim type 48" door (panic grade).
- 3.8000 / 8500 - 36 Alarm rim type 36" door (fire grade).
- 4.8000 / 8500 - 48 Alarm rim type 48" door (fire grade).

Dimensions

Alarm units has an internal horn. when the push rail is depressed, the horn sound to provide an means of signaling that the door has been opened and violated.

The unit has changeable " 1 / 3 / 5 / no limit " minute, alarm cut off or manual reset. Preset at factory for 1 minute alarm cut off.

The key switch to turn the alarm off is a standard 1-1/4" cylinder with "C " keyway. The alarm operates on one standard 9 volt transistor battery. when battery is weak the horn will emit an intermittent signal.

Alarm unit supplied with a switch to monitor push rail, latchbolt are secured by guardbolt design.

Unit includes "EMERGENCY EXIT ONLY ALARM WILL SOUND" decal for application on door or unit.

INSTALLATION INSTRUCTION FOR 5000 / 5500 & 8000 / 8500 SERIES ALARMING DEVICE

1.Ass'y Alarming kit with parts as shown below:

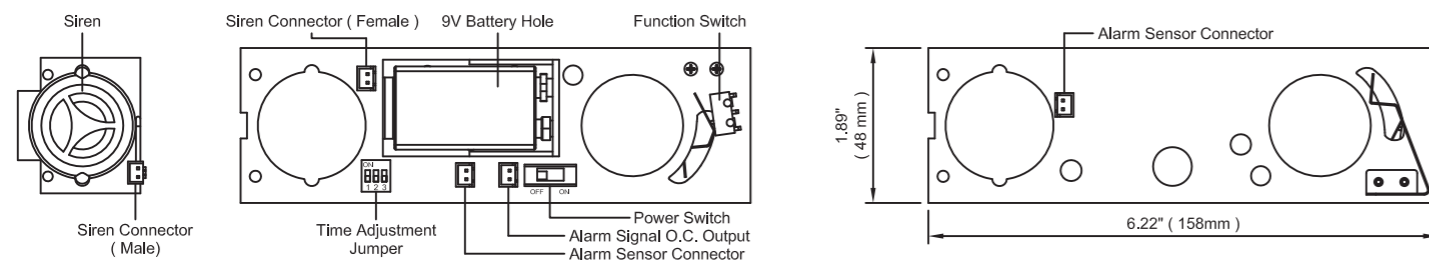
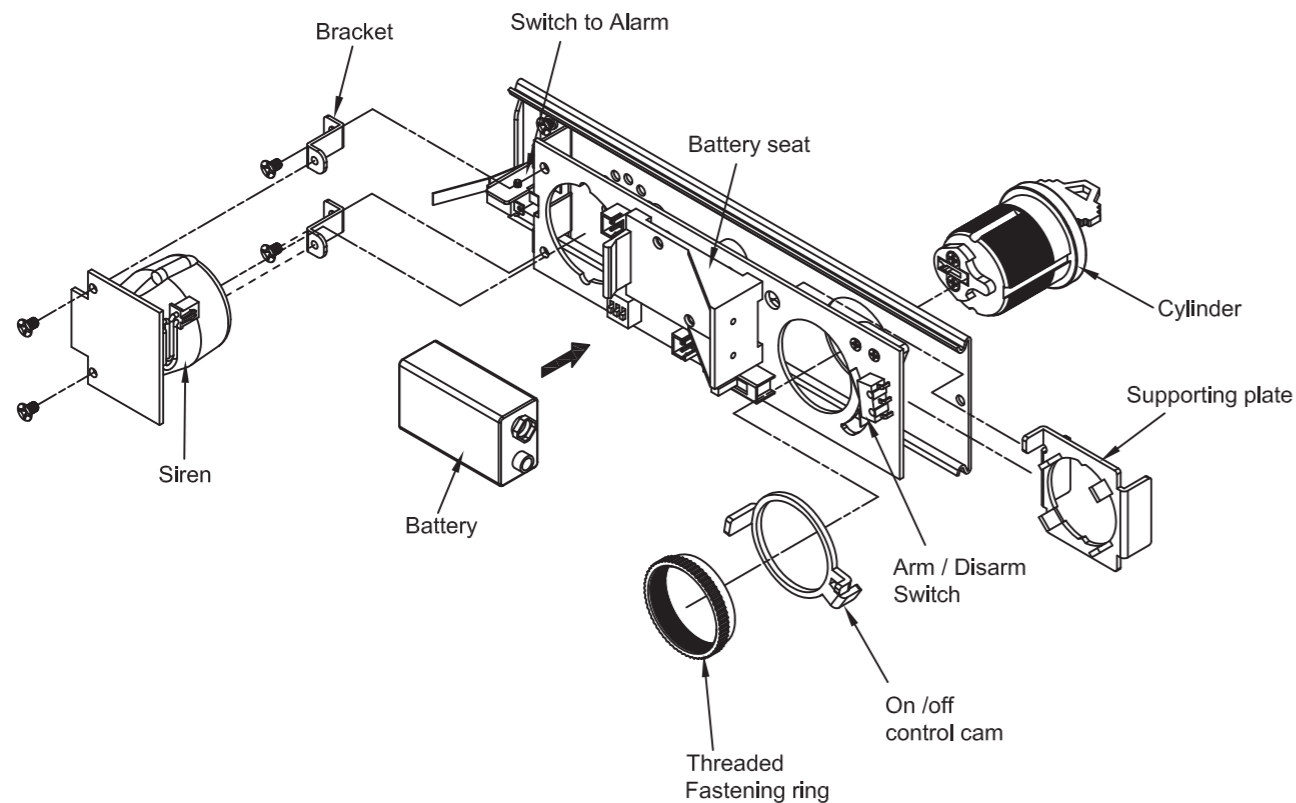

1-1.Operation:

- (1).Place the 9V 6LR61 lithium battery onto the panel and turn on power switch.
- (2).To adjust the alarm time , kindly set the jumper as shown below :

Alarm time	Jumper Setting	Figure
1 Min.	DIP1 set	
	DIP2 and DIP3 not set	
3 Min.	DIP2 set	
	DIP1 and DIP3 not set	
5 Min.	DIP3 set	
	DIP1 and DIP2 not set	
No Limit	DIP1 , DIP2 , DIP3 not set	

Cam should be to Off position before Battery installed

Push leaf spring in correct direction in install step 3.

- 2.Cut the Device and/or Sliding shim (end opposite Cyl. hole) to proper length.
- 3.Install Device to door.
- 4.Then sliding in the Alarm kit.
- 5.Mount the Exit Device end cover.
- 6.Mount sign by peeling off the protective backing and sticking onto Push Rail.

Operating Instruction

- 1.Insert key into Cyl. and arm the unit by turning key Anti-clockwise to arm.
- 2.Depress push rail, alarm should sound immediately.
- 3.Turn key clockwise to Disarm.

Operating Instruction

- 1.Alarm unit has an internal horn. When rail pushed, alarm will sound.
- 2.Place the 9V lithium battery onto the panel and turn on power switch.
- 3.The unit has changeable " 1 / 3 / 5 / no limits " minutes alarm cut off or manual reset. Preset at factory for 1 minutes alarm cut off.
- 4.Key switch to turn off the alarm.1-1/4" cyl with "C" keyway. Clockwise turn Disarm, silence or deactivates the alarm. And anti-clockwise turn Arm.
- 5.Alarm operate with a standard 9-volt transistor battery.
- 6.When low battery, a brief signal is emitted intermittently.
- 7.Alarm unit supplied with a mag reed switch. to monitor push rail latchbolt for full proof secured.
- 8.Unit includes Red " Emergency Exit only Alarm will Sound " decal for application on door or unit.

