

TEMPLATE FOR #500 PANIC EXIT DEVICE RIM PANIC EXIT DEVICE MODELS ED501 & EDS551

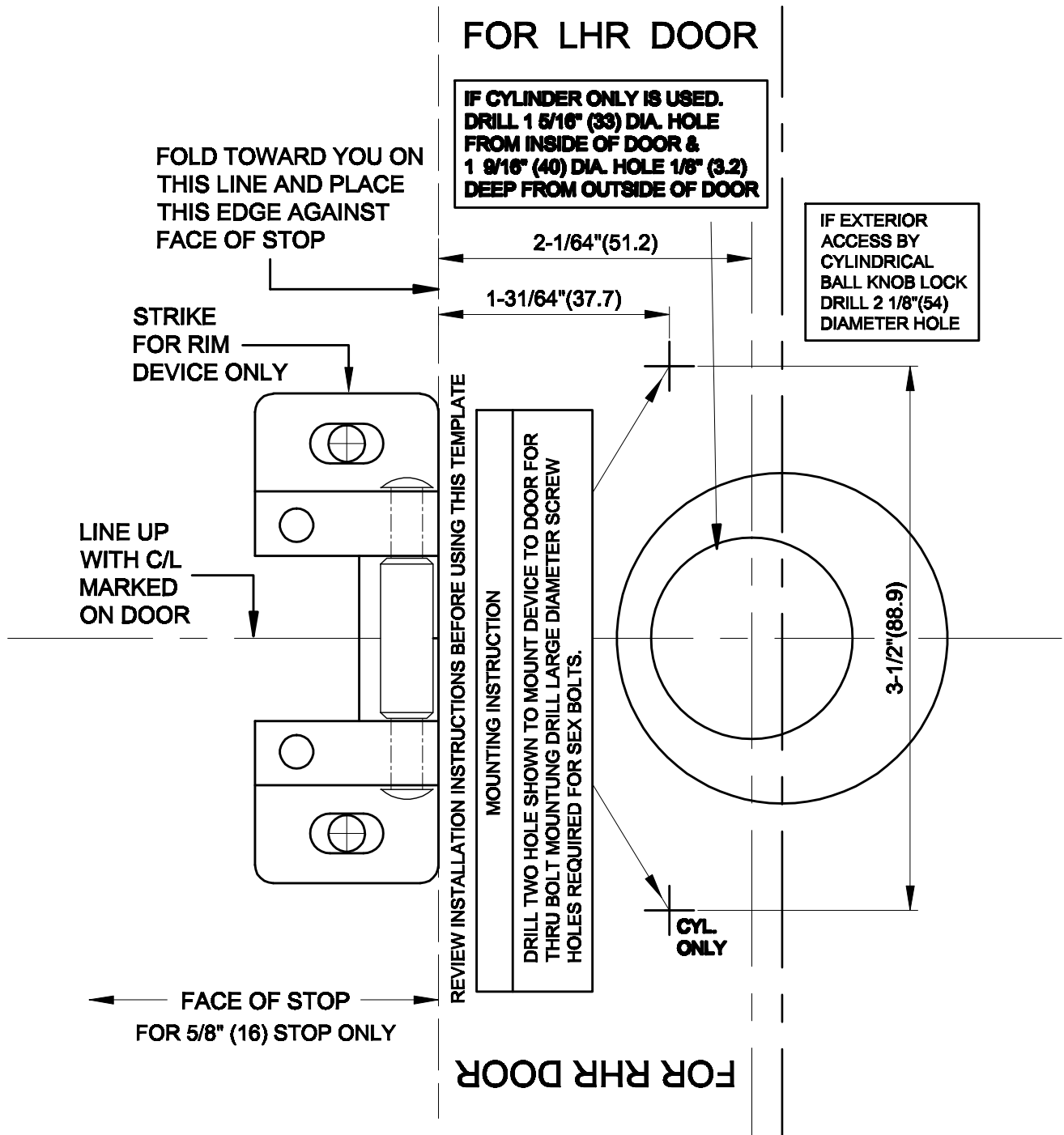

TEMPLATE FOR #500 PANIC EXIT DEVICE RIM PANIC EXIT DEVICE MODELS ED501 & EDS551

INSTALLATION INSTRUCTIONS FOR 500 SERIES RIM EXIT DEVICE REVERSIBLE (NON HANDED)

POSITIONING EXIT DEVICE

A. CENTER LINE

Position the center line for the device 40 5/16" (1024) above floor. Draw a line across door & frame.

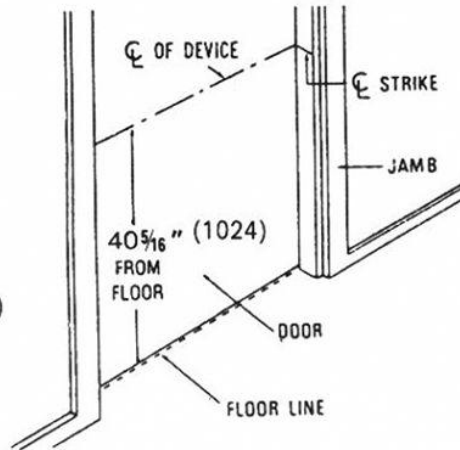

SEE PAGE 6 FOR SCREW
AND DRILL SIZE CHART

PLEASE NOTE:

IF DOOR HAS PREPARATION FOR 2 3/4 (70) BACKSET CYLINDRICAL LOCK, MOUNT PANIC STRIKE USING CENTER OF 2 1/8 (54) DIAMETER LOCK HOLE

WHEN YOUR DOOR HAS CYLINDRICAL LOCK CUT-OUT FOR ANSI A115.2 AND A115.3 PREP DOORS.

1. Extend horizontal and vertical center lines of cut-out shown at sight.
2. If frame has 5/8" (16) stop, align center lines on template with center lines on door. Stop and drill template holes as described above and follow steps three thru six.
3. If frame has 1/2" (12.7) stop, align center lines on Template with center lines on Door and spot mounting holes for LATCH ASSEMBLY ONLY. Then MOVE Template up against stop and spot mounting holes for Strike. Drill two mounting holes. Now follow steps three thru six. Note special Shim shown at right, which is mounted beneath Strike.

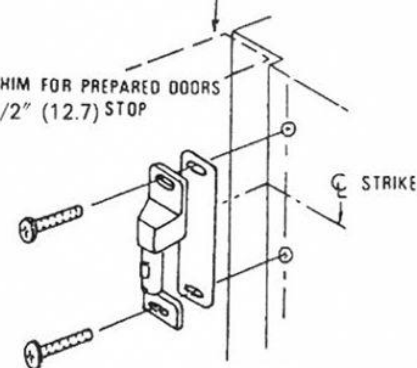
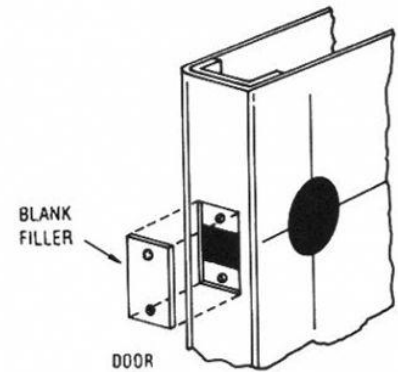

Shim always furnished as standard part package

B. LOCATE AND DRILL TEMPLATE HOLES

With template furnished, locate and drill mounting holes for Trim, Device and Strike.

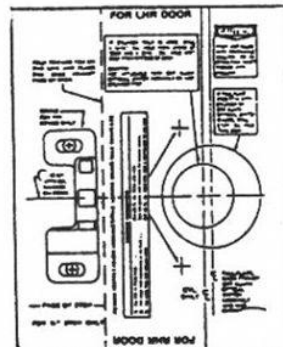

C. INSTALLATION FOR KNOB LOCK TRIM & STRIKE

ALWAYS REFER TO TEMPLATE
PACKED WITH TRIM BEFORE
PROCEEDING WITH INSTALLATION

CUT OFF LENGTH OF CYLINDER CONNECTING BAR SO THAT
1/2" (12.7) PROJECTS BEYOND INSIDE FACE OF DOOR.

KNOB TRIM

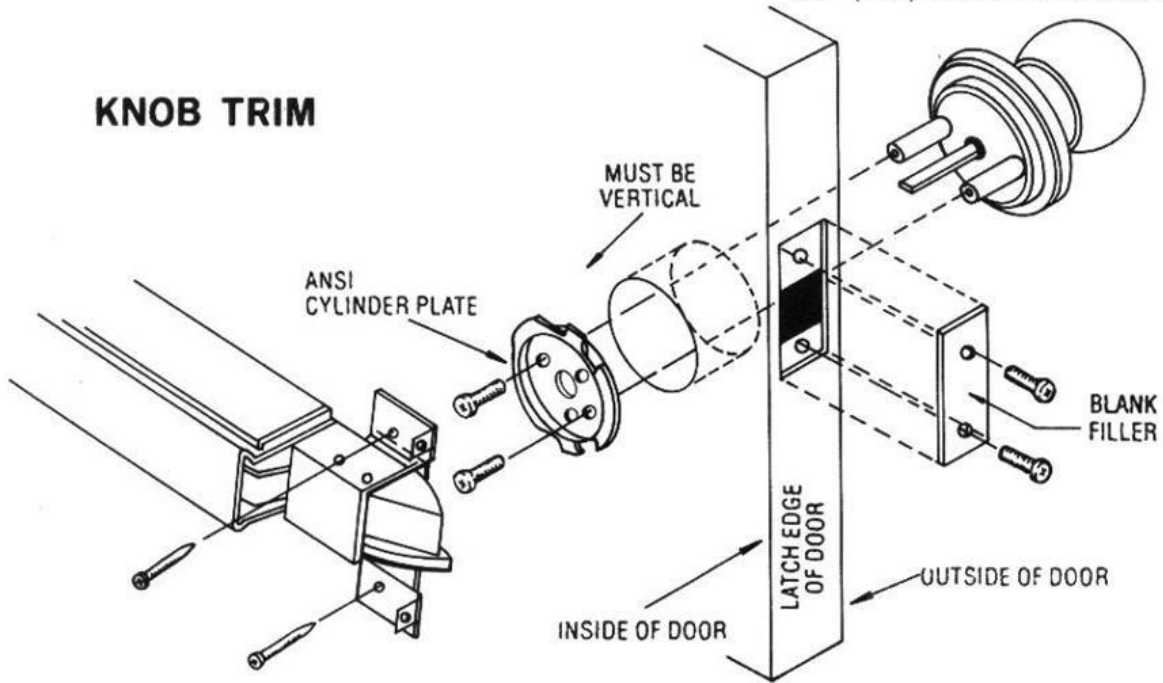

MOUNT KEYWAY IN KNOB VERTICALLY AS SHOWN

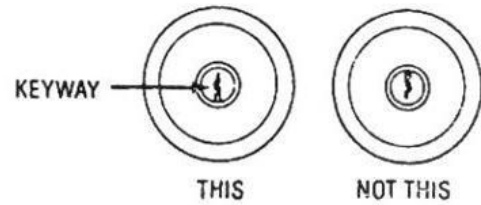

PLEASE NOTE AND BE CAREFUL

WHEN USING THE ANSI CYLINDER PLATE BE SURE
THE BOSSES ON THE LATCH ASSEMBLY FIT INTO
THE CUTOUTS ON THE CYLINDER PLATE SO THAT
THE LATCH ASSEMBLY LIES FLAT ON THE DOOR.

VIEW REVERSED TO
SHOW PROPER MATING
POSITION WHEN INSTALLED.

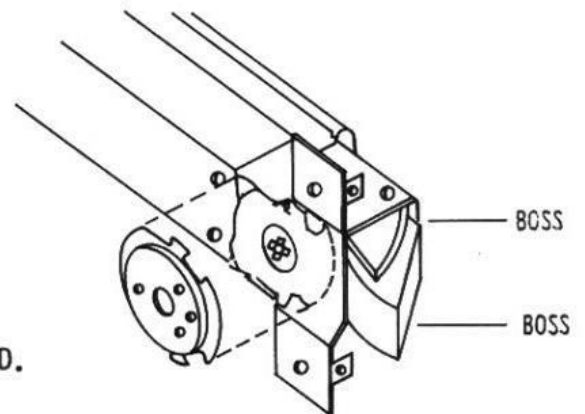

D. INSTALL TRIM & STRIKE

PULL AND PLATE TRIM

MOUNT CYLINDER HORIZONTALLY AS SHOWN. CUT OFF LENGTH OF CYL. CONNECTING BAR SO THAT 1/2" (12.7) PROJECTS BEYOND INSIDE FACE OF DOOR.

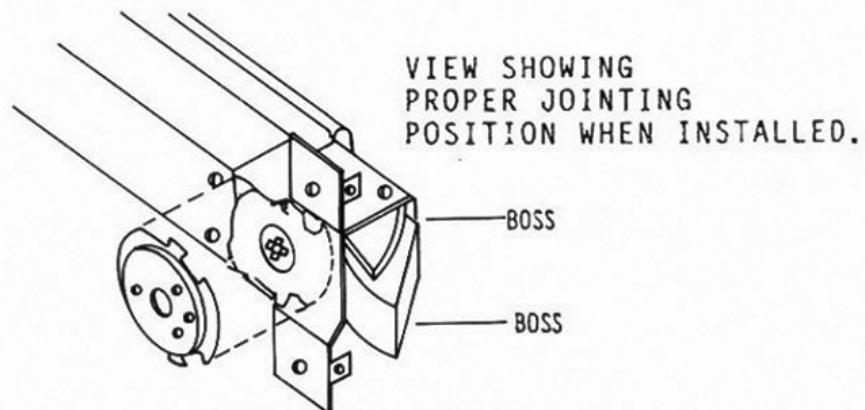
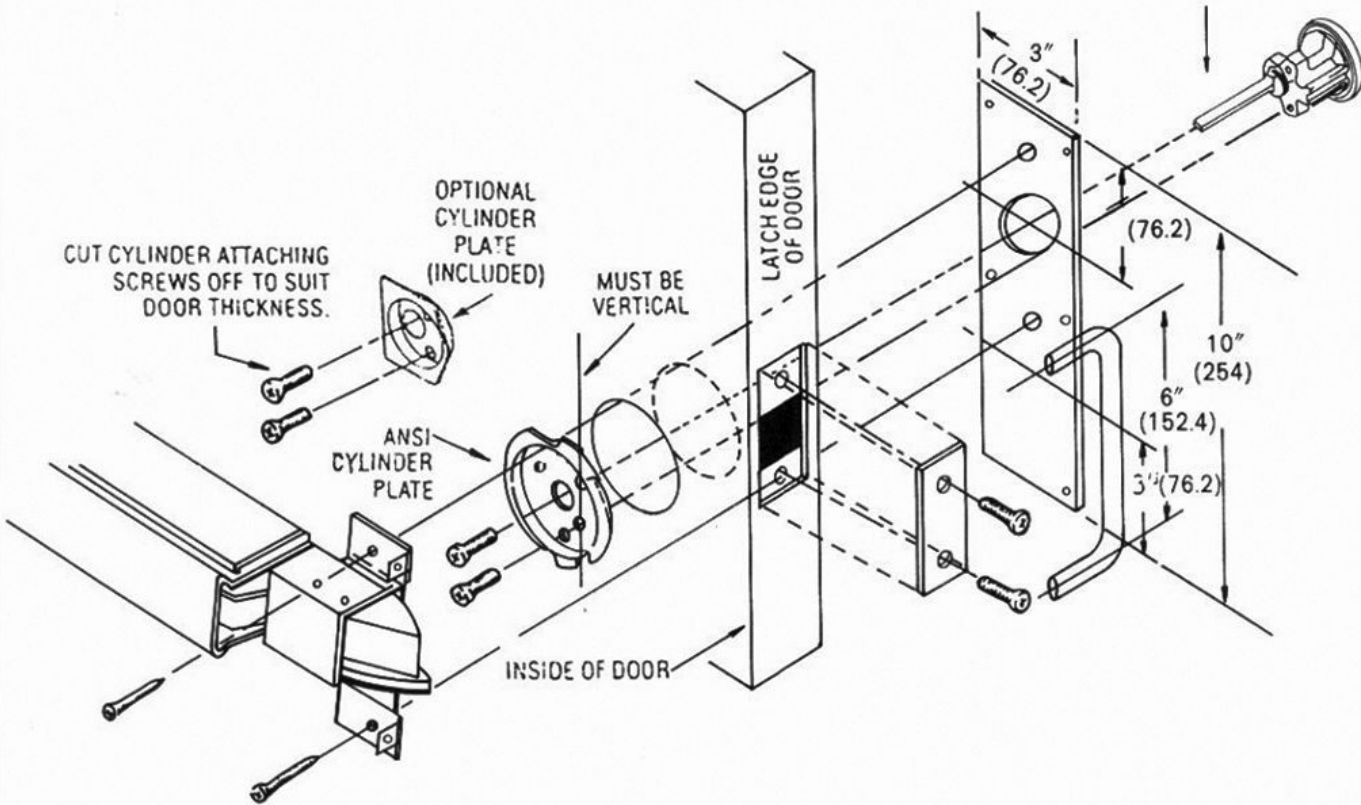

PLEASE NOTE AND BE CAREFUL WHEN USING THE ANSI CYLINDER PLATE BE SURE THE BOSSES ON THE LATCH ASSEMBLY FIT INTO THE CUTOUTS ON THE CYLINDER PLATE SO THAT THE LATCH ASSEMBLY LIES FLAT ON THE DOOR.

D-1. INSTALL TRIM AND STRIKE (CONT.)

PULL AND PLATE TRIM FOR REGULAR AND FIRE RATED DEVICES LA

CAUTION: REFER TO TEMPLATE PACKED WITH TRIM BEFORE PROCEEDING WITH STEP 3.

MOUNT CYL HORIZONTALLY AS SHOWN.
CUT OFF LENGTH OF CYL. CONNECTING BAR SO THAT 3/16" (4.8) PROJECTS BEYOND INSIDE FACE OF DOOR.

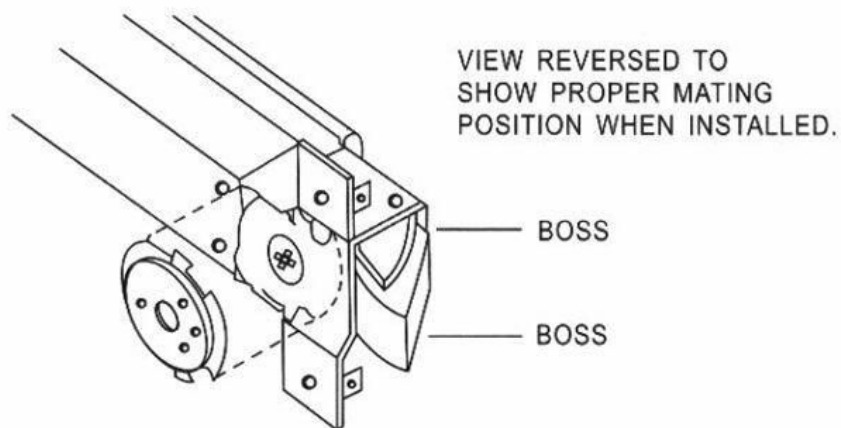
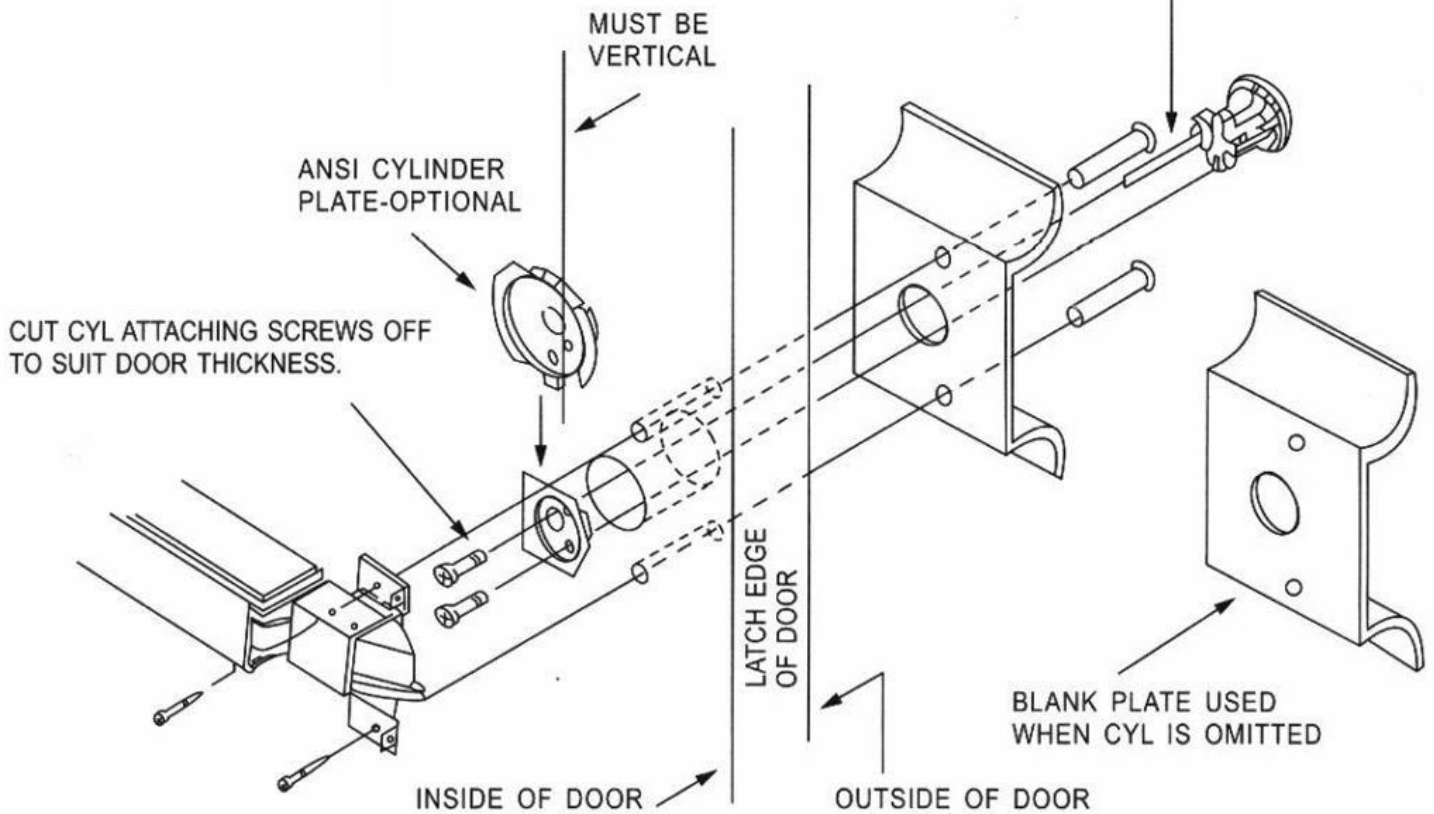

CAUTION:
WHEN USING THE ANSI CYLINDER PLATE BE SURE THE BOSSES ON THE LATCH ASSEMBLY FIT INTO THE CUTOUTS ON THE CYLINDER PLATE SO THAT THE LATCH ASSEMBLY LAYS FLAT ON THE DOOR.

E. IF CUTTING BAR IS NEEDED

BAR AND OVERALL CORRECT SIZE FOR A 36" (914.4) WIDE DOOR IF OK PROCEED TO NEXT STEP WITHOUT DOING ANYTHING.

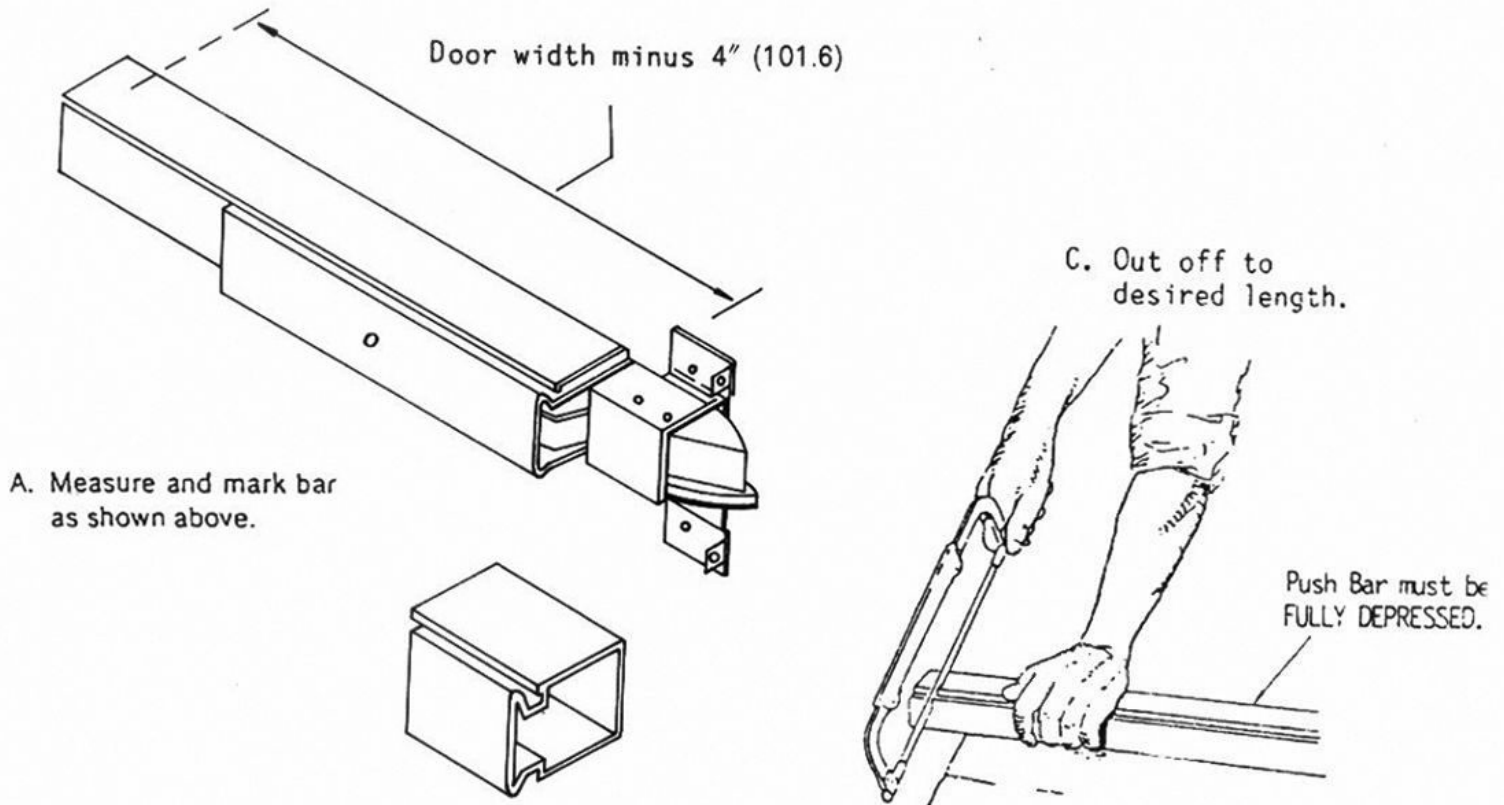

F. MOUNTING DEVICE

Attach Latch to door but do not tighten Screws. Assemble Rear Mounting Bracket to Push Bar (see nesting arrangement in exploded view). Use rear Mounting Bracket as a template to spot holes for Mounting Screws. Push Bar should be level. Drill Screw holes and attach Rear Mounting bracket and Plate to door. Secure Latch Screws and attach Front and Rear Covers.

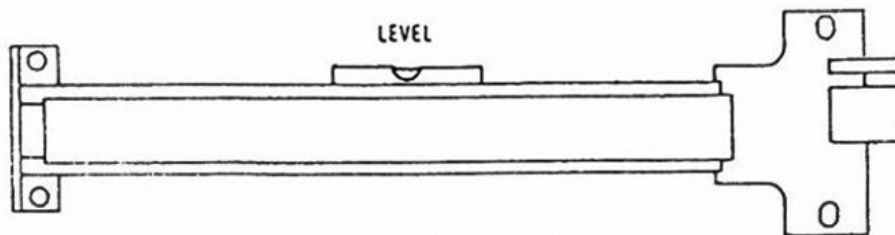

G. TO MOUNT DEVICE

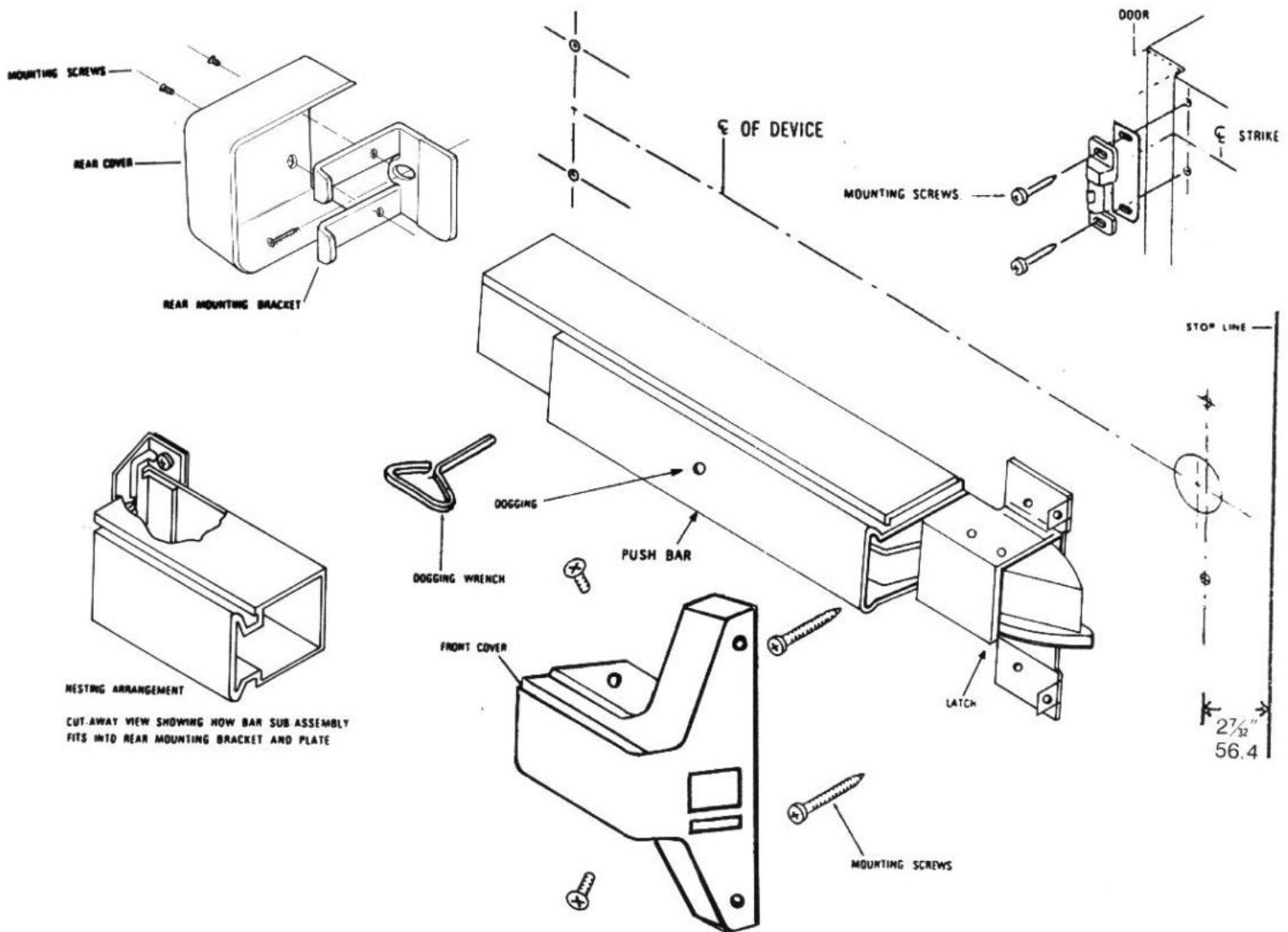

H. HOW TO TEST PUSH BAR & DOGGING DEVICE

Latch bolt is retracted by the push bar inside.

Latch bolt is retracted by the push bar inside and the key outside. Turning the key in either direction will retract the latch. Return key to the horizontal position to remove key and project latch.

Latch bolt is retracted by the push bar inside and the key or knob outside.

To lock knob: Insert key in cylinder and turn counter clockwise as far as key will turn. Then return key to its vertical position and withdraw key.

To unlock knob: Insert key in cylinder and turn clockwise as far as key will turn (the latch will retract during this procedure). Then return key to its vertical position and withdraw key.

Dogging: Depress push bar. Insert dogging wrench and turn clockwise 90°. The push bar will remain depressed and the latch will remain retracted.

HOW TO REMOVE & REINSTALL CYLINDER IN LOCK

Remove knob:

1. Insert key in cylinder and turn 90° clockwise.
2. Insert knob removing tool into the hole in the knob and depress the knob catch button.
3. While knob catch button is depressed pull knob off.

(The knob catch button will be in one of these positions).

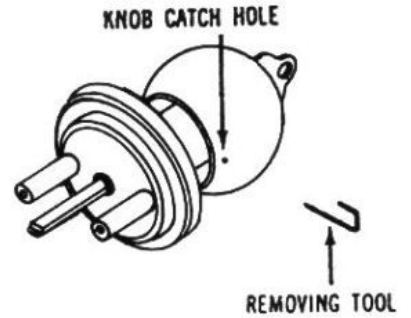
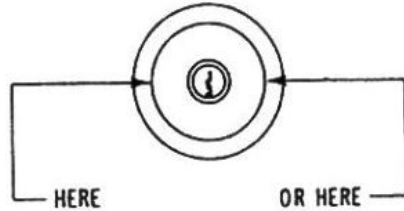

Remove cylinder from knob:

1. Remove sleeve.
2. Remove key.
3. Slide cylinder out of knob.

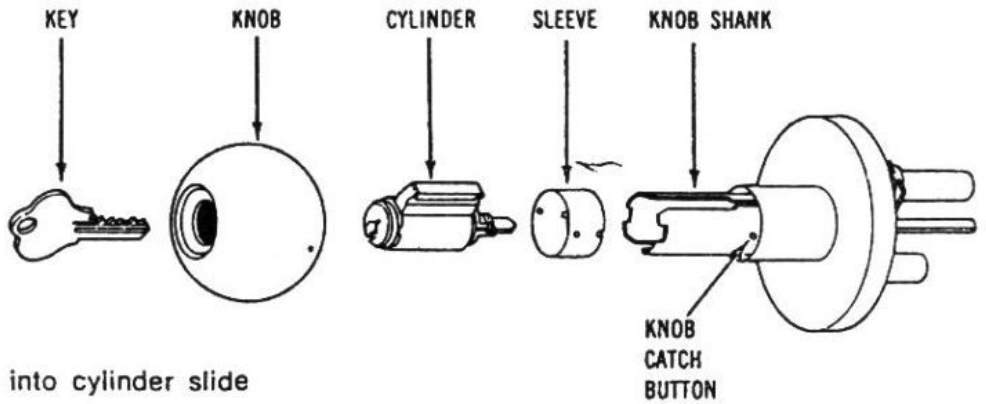

Reinstall cylinder in knob:

1. Slide cylinder into knob.
2. Replace sleeve.

Reinstall knob:

1. With key inserted part way into cylinder slide knob onto knob shank.
2. Depress knob catch button and push knob on to the knob shank as far as it will go.
3. Insert key completely into the cylinder and turn the key while pushing on the knob until it engages the knob catch button.
4. Return key to its vertical position and remove it.
5. Pull on the knob to be certain it is properly engaged to the knob catch button.

TWIST DRILL SIZES

Screw Diameter	*Machine Screws	Self Tapping Screws			
		All Door Gauges	24 GA.	20 GA.	18 GA.
#8	# 29 (3.5)	1/8" (3.2)	1/8" (3.2)	# 30 (3.3)	# 29 (3.5)
#12	# 16 (4.5)	# 19 (4.2)	# 19 (4.2)	# 18 (4.3)	# 16 (4.5)

*Machine screws are intended for use with doors having sufficient metal thickness for proper tapping (reinforced doors) or sex bolts.

SCREW CHART

Item	Qty.	Fastener
Front plate assembly and rear bracket	4	#12x1-1/4" Lg. pan head tapping screws type "A"
Strike	2	#12x1-1/4" Lg. pan head tapping "screws type "A"
Edge Filler	4	2 #8-32x1/2 machine screw, 2 #8x1 pan hd, tapping screw.
Strike Filler	4	#12-24x1/2 flat hd, machine screw, 2 #12x3/4, pan hd, tapping screw.

Drill sizes for screws are recommended but various factors, such as type of door and frame construction, thickness and type of metal, etc. can affect the final hole diameter and resulting holding strength of the fastener.

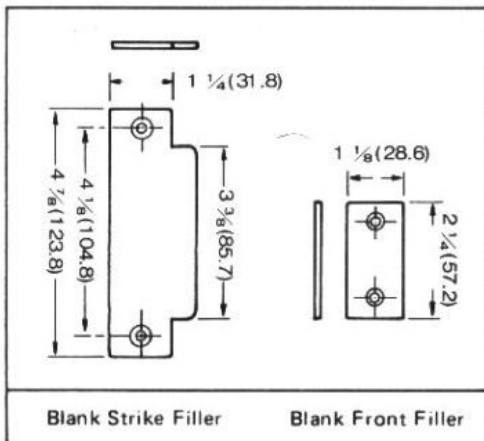

CAUTION

CAUTION: IF EXIT DEVICE BAR NEEDS TO BE CUT, IT IS CRITICAL THE EXIT DEVICE COVER BE PROPERLY CUT. PLEASE FOLLOW THE DIRECTIONS BELOW TO AVOID POSSIBLE INJURY AFTER INSTALLATION.

- A) DEPRESS PUSH BAR UNTIL STEP "B" IS COMPLETE.
- B) WHILE THE PUSH BAR IS DEPRESSED, MOVE COVER INWARD TOWARD THE PUSH BAR UNTIL COVER EDGE TOUCHES THE PUSH BAR END.
- C) MEASURE AND MARK BAR AND COVER PIECES AS NEEDED AND SHOWN.
- D) USE MASKING TAPE TO PROTECT AND SECURE THE COVER AND BAR SECTION WHEN CUT.
- E) CUT THE COVER AND BAR TO DESIRED LENGTH.
- F) CUTTING PROCESS IS COMPLETE.

IF CUTTING BAR IS NEEDED

