

# INSTRUCTIONS FOR INSTALLING EDCVW701 / EDFCVW701 SERIES CONCEALED VERTICAL ROD EXIT DEVICE

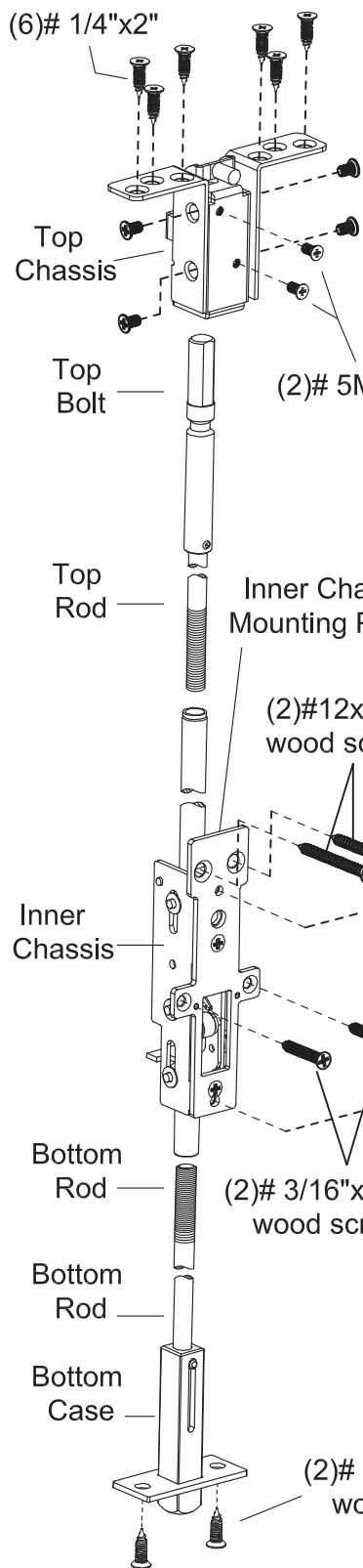

Available stock length  
 - For 32" doors, Device can be cut to fit doors down to 24" wide.  
 - For 36" doors, Device can be cut to fit doors down to 32" wide.  
 - For 48" doors, Device can be cut to fit doors down to 36" wide.

THIS EXIT DEVICE IS HANDED  
 CHECK HAND OF DEVICE AGAINST APPLICATION

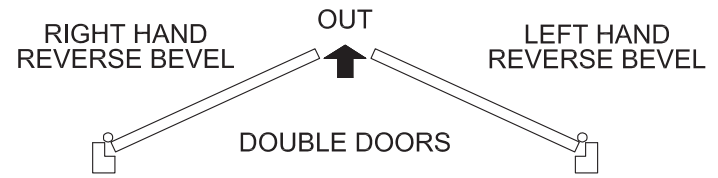

Door Surface must be flush to allow Exit Device rest on flat surface of the door

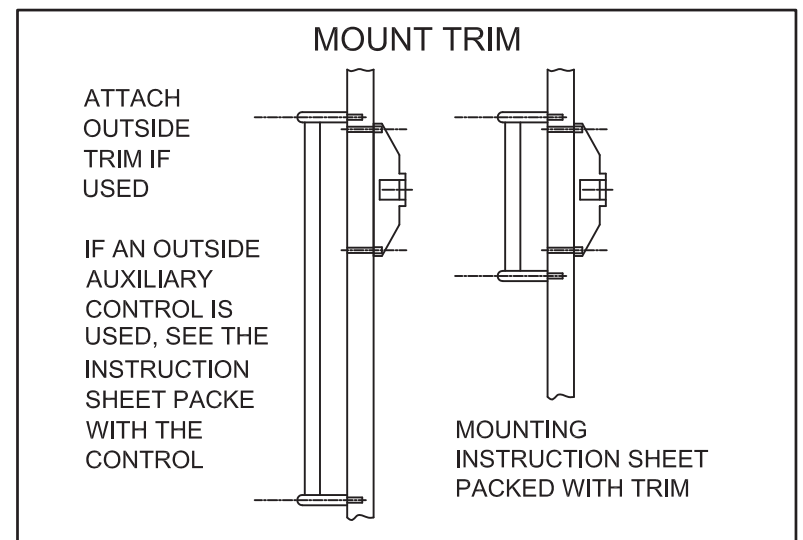
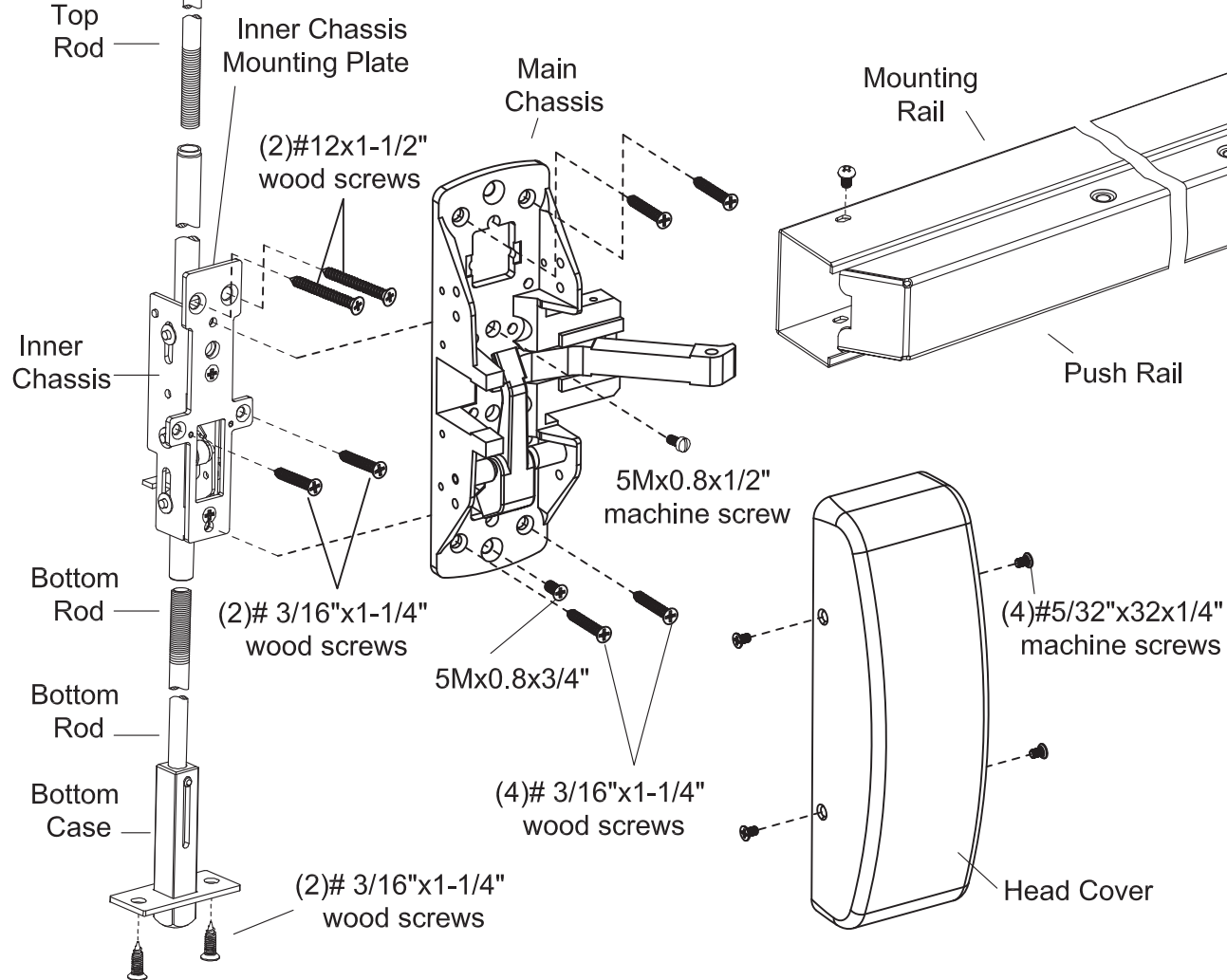
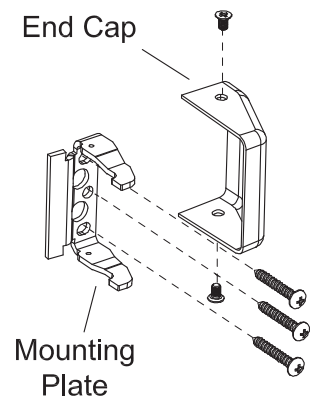
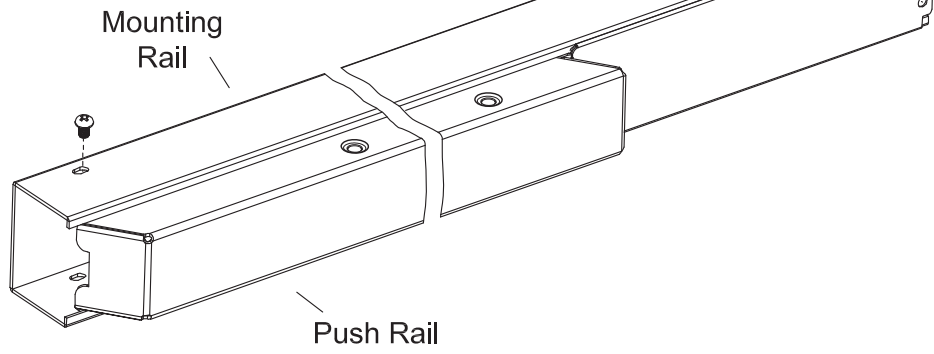

## INSTRUCTIONS FOR INSTALLING ESC LEVER TRIM FOR EDCVW701 / EDFCVW701 SERIES CONCEALED VERTICAL ROD EXIT DEVICE

1. Thru Inner Chassis cutout in the door, insert the extension in the door.
2. Insert Inner chassis in the cutout, and insert reduced end of extension in top threaded bushing on inner chassis, and fasten the rod extension with 1 machine screw.
3. On outside of door thru the cutout, install Plate into extension in the door.
4. Before attaching main chassis and inner chassis to the door, attach esc lever trim to the door with (2) 1/4-20 x 2-3/8" flat head machine screws.
5. Then attach Rail Ass'y to the chassis, and hinge stile end of rail to the door with mounting bracket.

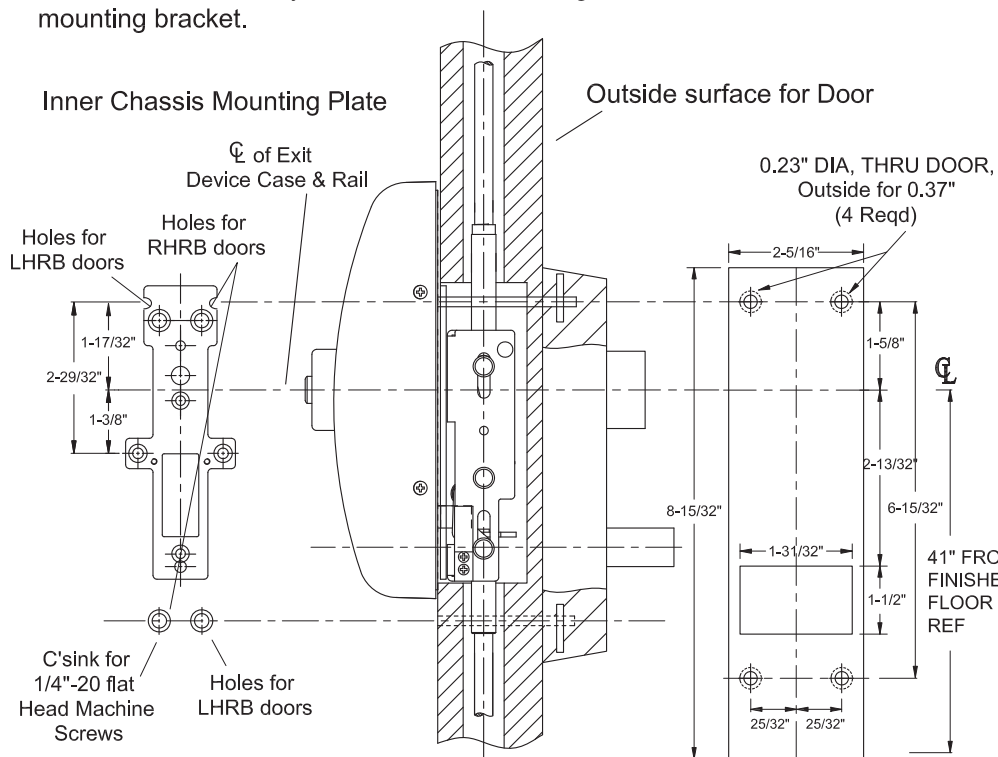

## INSTRUCTIONS FOR INSTALLING WOOD DOOR ESC TRIM EDCVW701 / EDFCVW701 SERIES CONCEALED VERTICAL ROD EXIT DEVICE

1. Thru Inner Chassis cutout in the door, insert the extension in the door.
2. Insert Inner chassis in the cutout, and insert reduced end of extension in top threaded bushing on inner chassis, and fasten the rod extension with 1 machine screw.
3. On outside of door thru the cutout, install Plate into extension in the door.
4. Attach mounting plate to inner chassis with 2 machine screws, then attach mounting plate to the door with 2 wood screws.
5. Attach WD Esc trim to the door. Then attach Rail Ass'y to the chassis, and hinge Stile end of rail to the door with mounting plate.

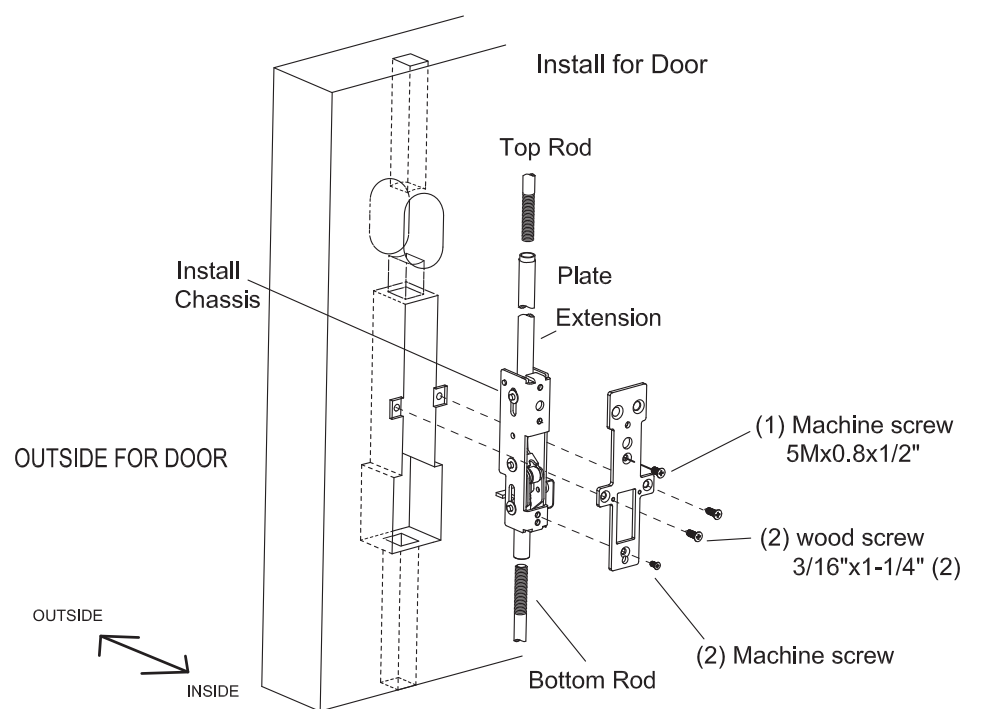

# INSTRUCTIONS FOR INSTALLING EDCVW701 / EDFCVW701 SERIES CONCEALED VERTICAL ROD EXIT DEVICE

## 1. PREPARE DOOR

And Prepare Top and Bottom Strike to Wood frame template

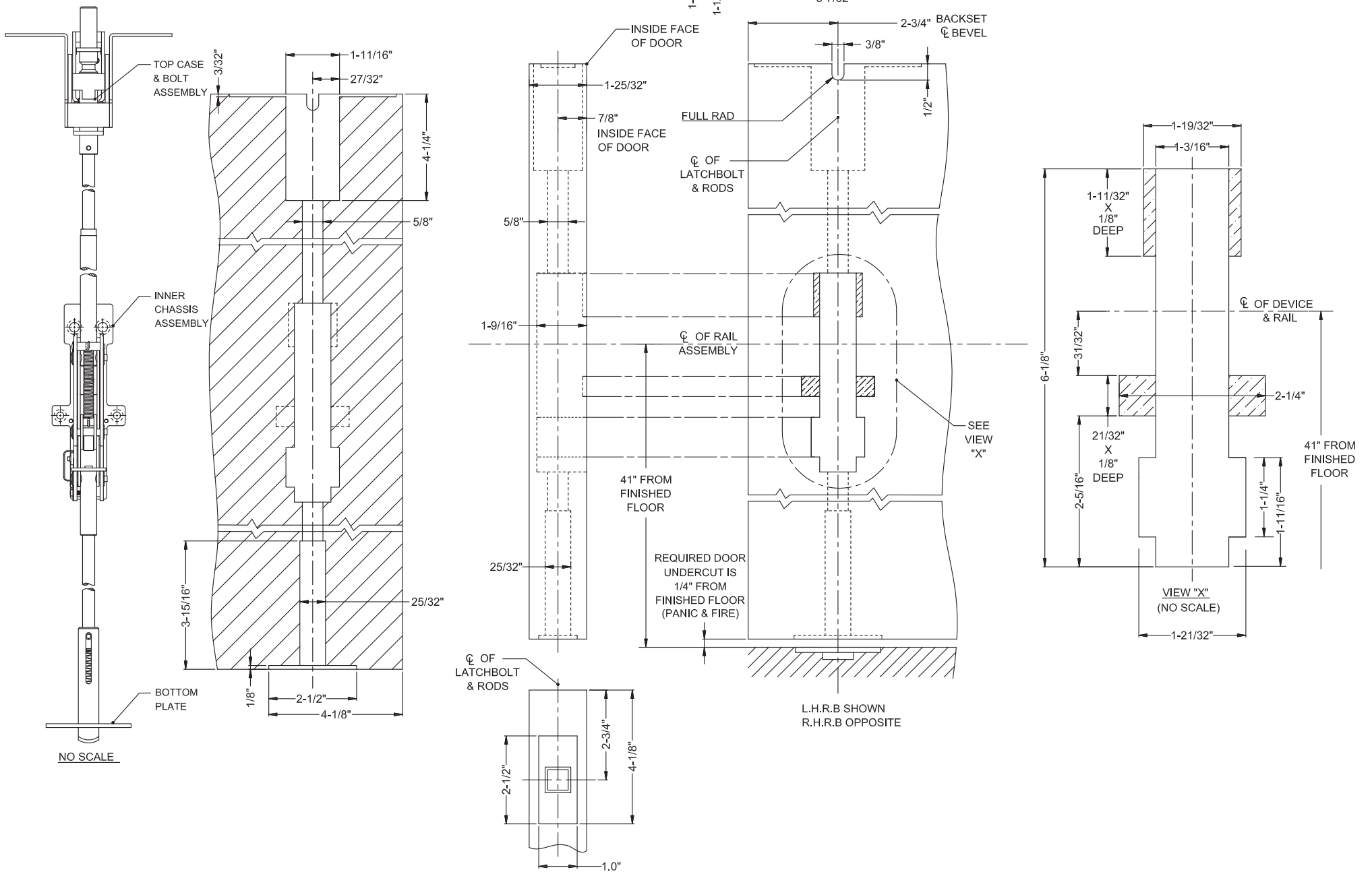

## 2. MOUNT ROD & CHASSIS

Use Strike Furnished

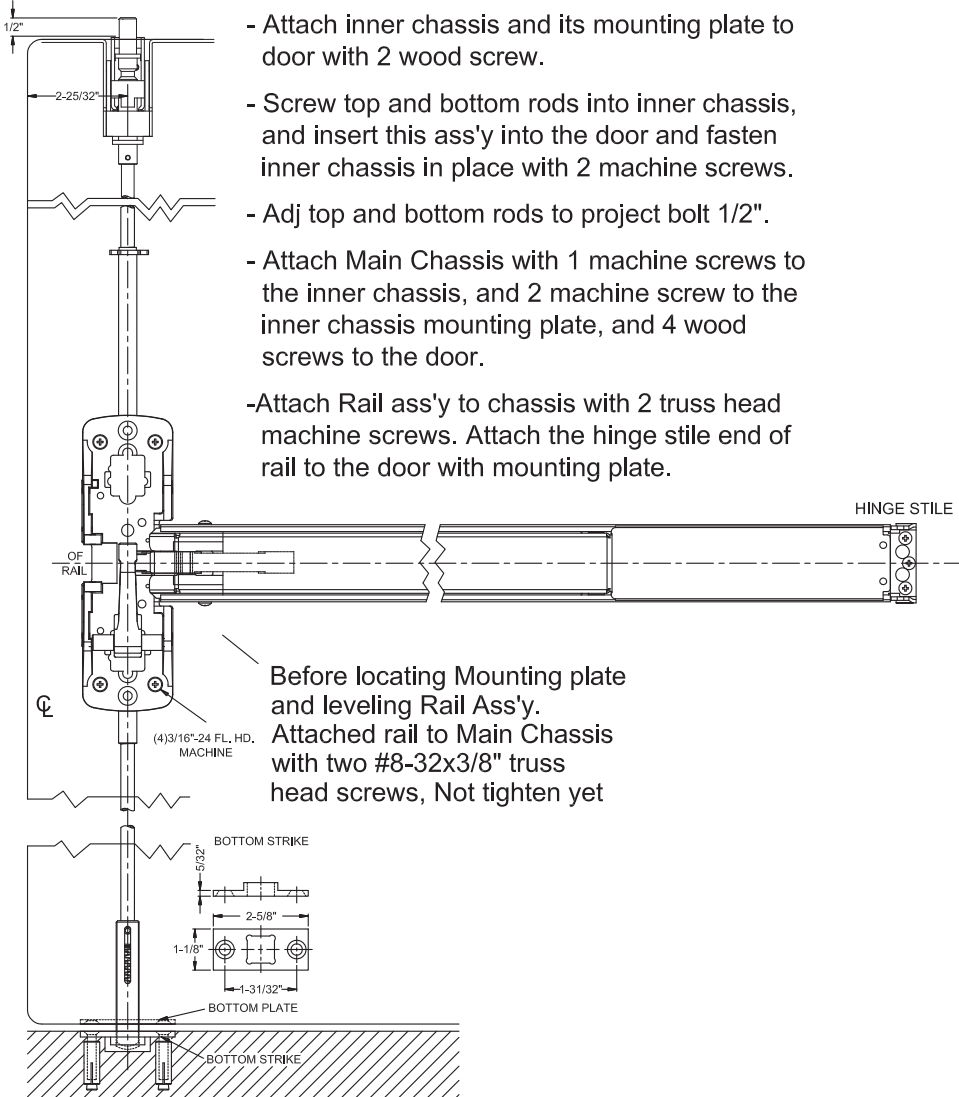

- Attach inner chassis and its mounting plate to door with 2 wood screw.
- Screw top and bottom rods into inner chassis, and insert this ass'y into the door and fasten inner chassis in place with 2 machine screws.
- Adj top and bottom rods to project bolt 1/2".
- Attach Main Chassis with 1 machine screws to the inner chassis, and 2 machine screw to the inner chassis mounting plate, and 4 wood screws to the door.
- Attach Rail ass'y to chassis with 2 truss head machine screws. Attach the hinge stile end of rail to the door with mounting plate.

Before locating Mounting plate and leveling Rail Ass'y. Attached rail to Main Chassis with two #8-32x3/8" truss head screws, Not tighten yet

## 3. MOUNT RAIL ASS'Y

3.1. Determine cut-off dimension "X" by subtracting 1-1/8" from dimension "Y".

3.2. Depress arm into rail opening and slide rail onto chassis.

3.3. With push rail depressed, adj top bolt flush with top of the door, and bottom bolt flush with bottom.

3.4. Insert top chassis into cutout at the top of the door, and attach with six wood screws.

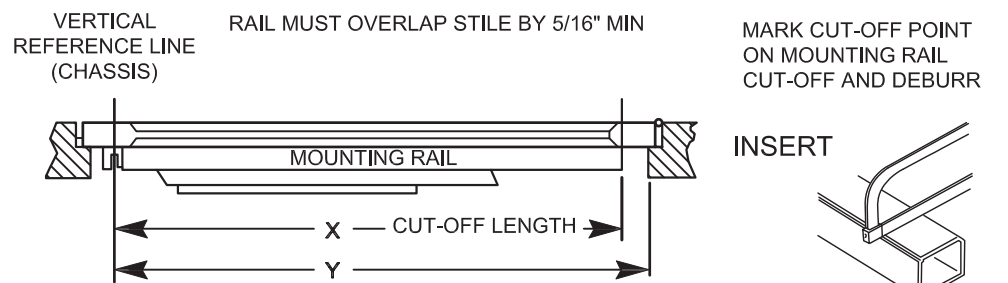

## 4. ATTACH COVER

- Attach end cap to mounting plate with two cover screws
- Attach cover to chassis with four cover screws.

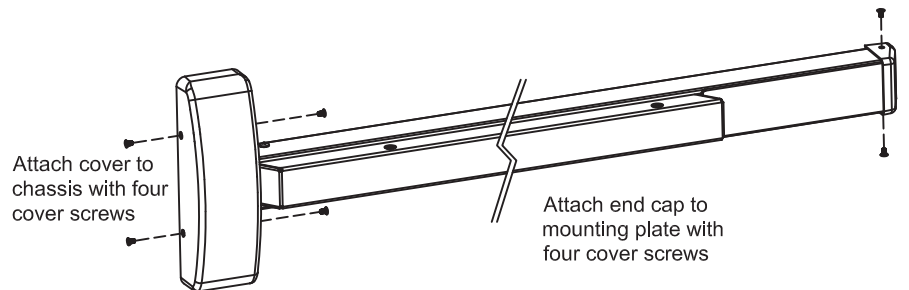

## 5. OPERATION CHECK

5.1. Depress Push rail, bolt should retract into door.

The latch retractor button should pop out and hold the bolt retracted until button is depressed.

5.2. If button does not pop out, remove top chassis and screw the top rod in one turn. Replace top chassis and repeat abv operation.