

# INSTALLATION INSTRUCTION FOR EDFV701-LBR SERIES FIRE VERTICAL ROD EXIT DEVICE.

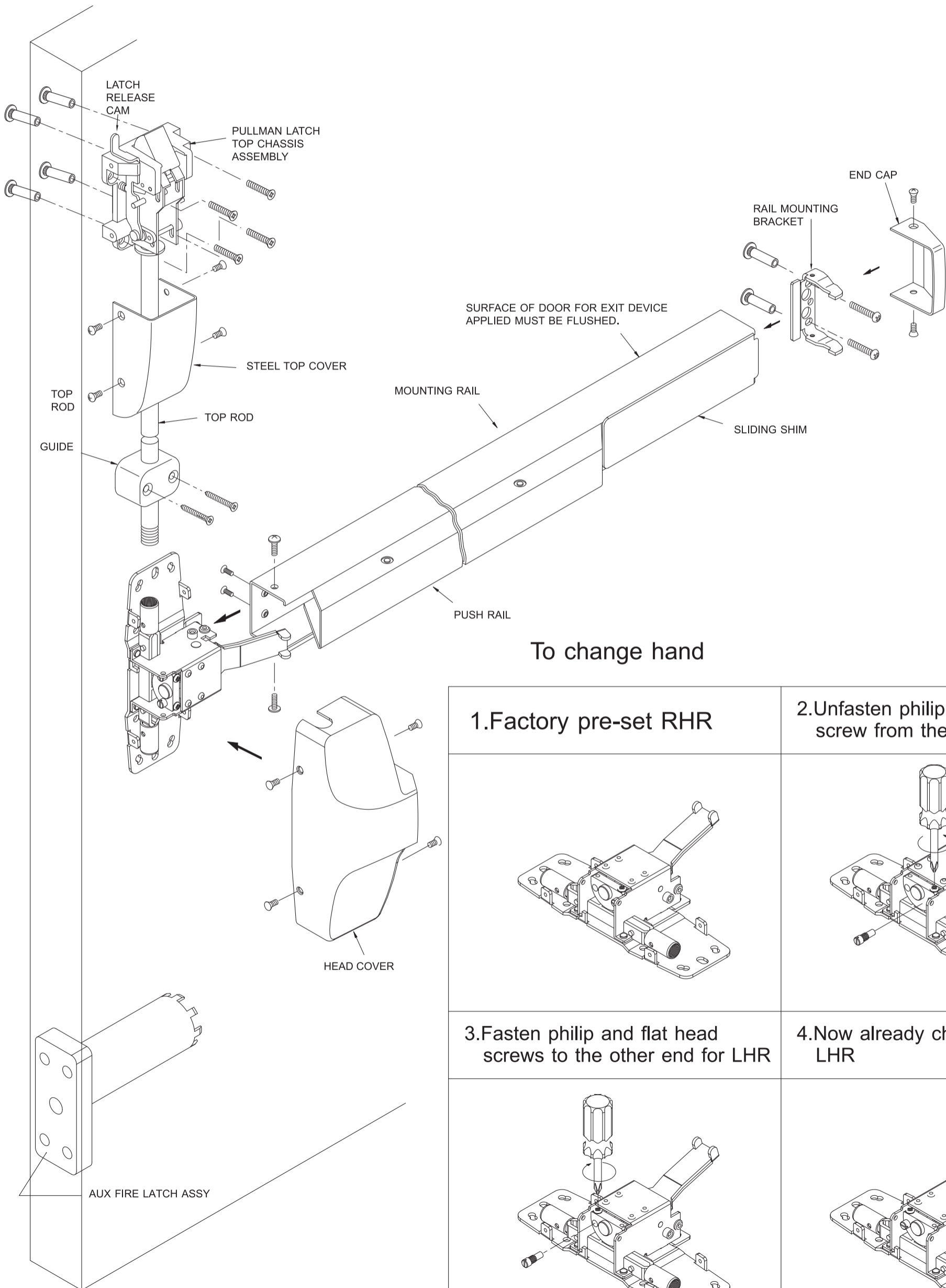

To change hand

1.Factory pre-set RHR

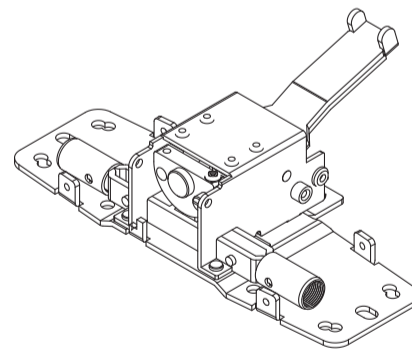

2.Unfasten philip and flat head screw from the pre-set RHR

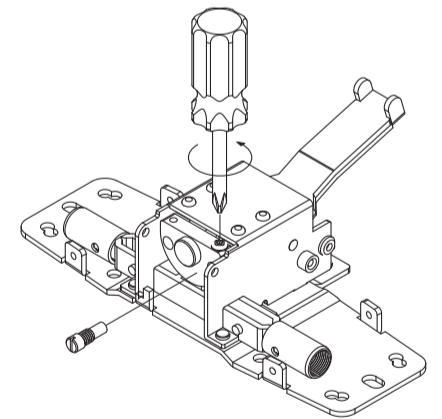

3.Fasten philip and flat head screws to the other end for LHR

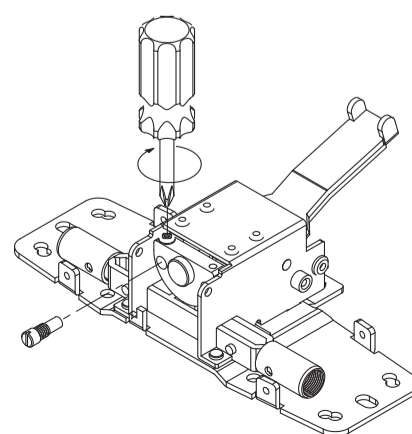

4.Now already changed to LHR

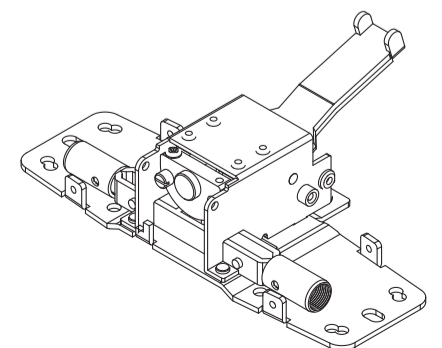

# 1. MARK VERTICAL AND HORIZONTAL REFERENCE LINE ON DOOR.

DETERMINE BACKSET TO LOCATE VERTICAL REFERENCE LINE.

1. IF LOCK STILE IS 4 1/2" WIDE OR WIDER, BACKSET IS 2 3/4".
2. IF LOCK STILE IS LESS THAN 4 1/2" WIDE, BACKSET IS HALF OF THE EXPOSED WIDTH OF LOCK STILE.

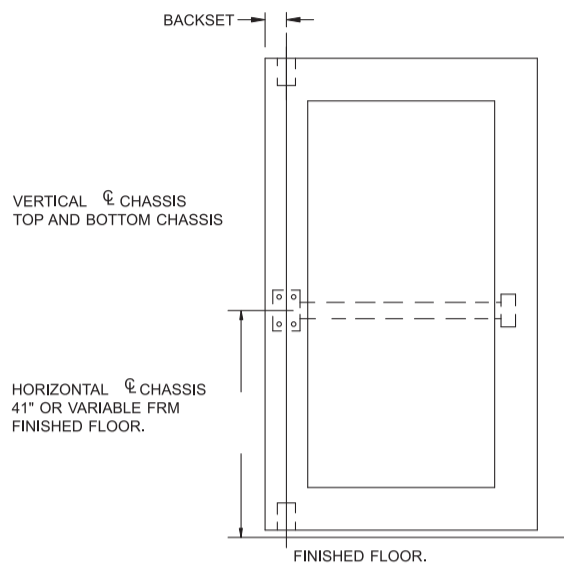

# 2. PREPARE DOOR

TAPE TEMPLATE ON INSIDE OF DOOR ALONG REFERENCE LINE. SPOT AND DRILL HOLE.

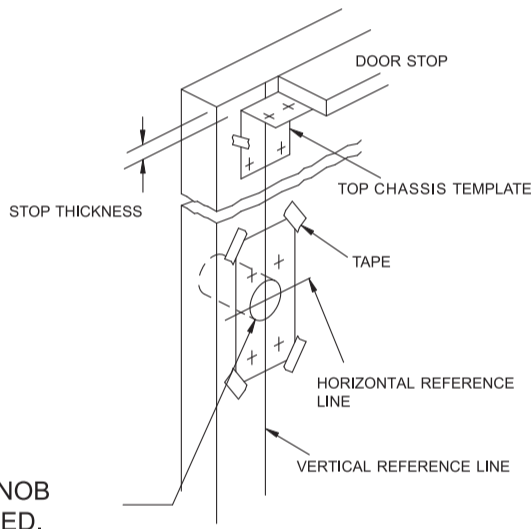

2 1/8"  $\varnothing$  BORE WHEN KNOB AND LEVER TRIM IS USED.

# 3. APPLY TRIM+CHASSIS

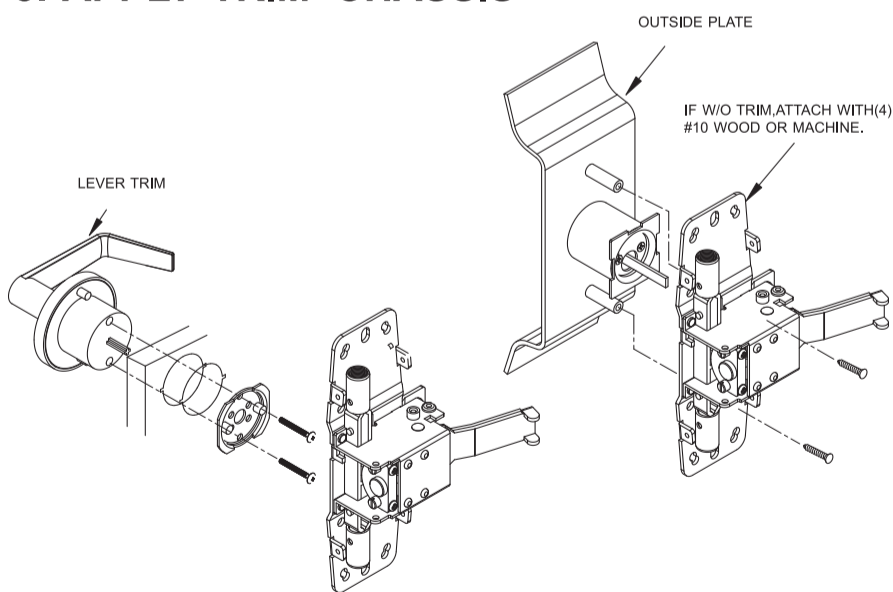

**BEFORE INSTALLING DEVICE, PLEASE CHECK :**

1. IF DOOR FITTED AND HUNG.
2. SIZE OF EXIT DEVICE, FUNCTION AND DESIGN...
  - 2.1. 36" DOORS, CAN BE CUT TO FIT DOORS DOWN TO 30" WIDE.
  - 2.2. 48" DOORS, CAN BE CUT TO FIT DOORS DOWN TO 36" WIDE.
  - 2.3. HAND OF DEVICE AGAINST APPLICATION

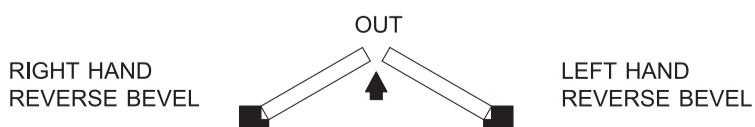

# 4. ATTACH TOP AND BOTTOM CHASSIS

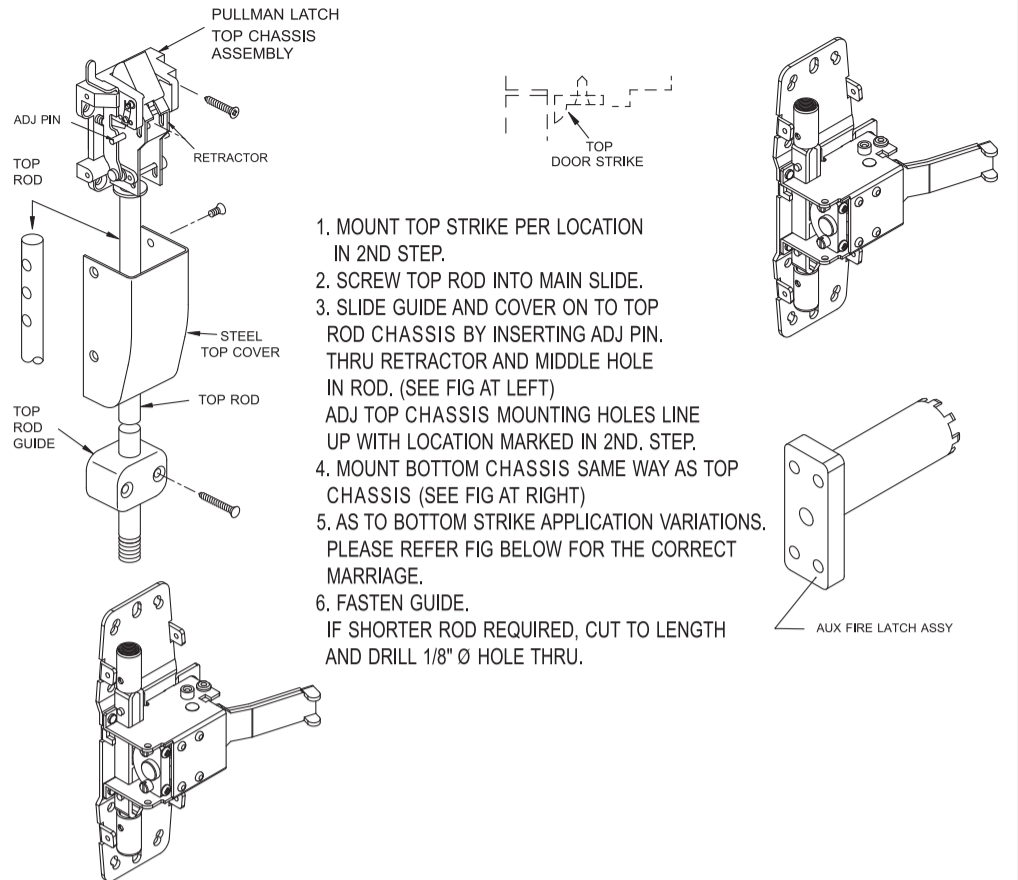

1. MOUNT TOP STRIKE PER LOCATION IN 2ND STEP.
2. SCREW TOP ROD INTO MAIN SLIDE.
3. SLIDE GUIDE AND COVER ON TO TOP ROD CHASSIS BY INSERTING ADJ PIN. THRU RETRACTOR AND MIDDLE HOLE IN ROD. (SEE FIG AT LEFT)
4. MOUNT BOTTOM CHASSIS SAME WAY AS TOP CHASSIS (SEE FIG AT RIGHT)
5. AS TO BOTTOM STRIKE APPLICATION VARIATIONS. PLEASE REFER FIG BELOW FOR THE CORRECT MARRIAGE.
6. FASTEN GUIDE. IF SHORTER ROD REQUIRED, CUT TO LENGTH AND DRILL 1/8"  $\varnothing$  HOLE THRU.

# 5. APPLY RAIL ASSEMBLE

1. CHECK THE SIZE OF DEVICE, IF CUTTING TO LENGTH IS REQUIRED.
2. DETERMINE CUT OFF LENGTH "X" BY SUBTRACTING 1 3/4" FROM "Y". MARK CUT OFF POINT ON MOUNTING RAIL.

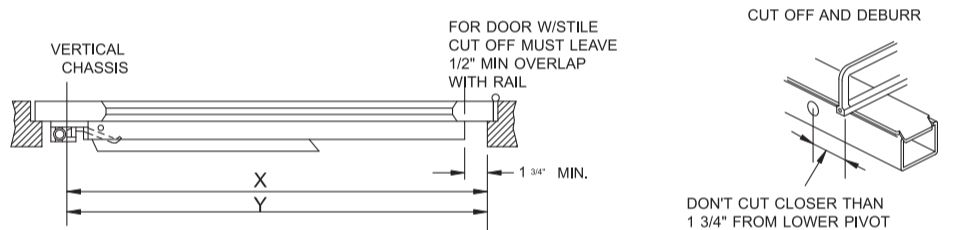

3. DEPRESS ARM INTO RAIL OPENING AND SLIDE RAIL ONTO CHASSIS. LEVEL RAIL AND FASTEN CHASSIS AND MOUNTING PLATE.

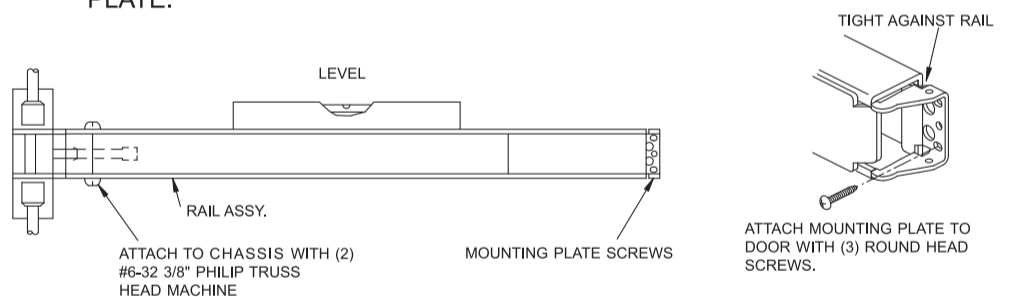

# 6. APPLY COVER

CHECK FINAL OPERATION OF DEVICE AND ADJUST THEN FASTEN COVERS.

